

Weights

Operating weight	1711 kg
Additional weight for cab with heating	96 kg
Additional weight for long dozer blade	9 kg
Ground pressure with rubber tracks	29.40 kPa

Engine

Make / model	Kubota / D722-E2B-BCZ-7
Fuel	Diesel
Number of cylinders	3
Displacement	0.72 L
Maximum NET power (ISO 9249)	9.9 kW
Maximum NET torque (ISO 9249)	42.3 Nm

Performance

Digging force, dipperstick (ISO 6015)	9108 N
Digging force, bucket (ISO 6015)	16177 N
Drawbar pull	14334 N
Travel speed, low range	2.0 km/h
Travel speed, high range	3.2 km/h

Hydraulic System

Pump type	Triple gear pump
Pump capacity	32.50 L/min
Pump 1 capacity at 2500 RPM	10.00 L/min
Pump 2 and 3 capacity at 2500 RPM	11.25 L/min
Auxiliary flow	32.50 L/min
Auxiliary relief	227.0 bar
Boom port relief base and rod end	210.0 - 250.0 bar

Slew System

Boom swing, left	80.0°
Boom swing, right	60.0°
Slew rate	8.7 RPM

Fluid Capacities

Cooling system	3.30 L
Engine lubrication plus oil filter	3.30 L
Fuel reservoir	19.00 L
Hydraulic system	17.00 L

Environmental

Noise level LpA(EU Directive 2006/42/EC)	79 dB(A)
Noise level LWA(EU Directive 2000/14/EC)	93 dB(A)
Whole body vibration (ISO 2631-1)	0.74 ms ⁻²
Hand-arm vibration (ISO 5349-1)	1.42 ms ⁻²
Hand-arm vibration (ISO 5349-1) Uncertainty	0.37 ms ⁻²

Standard Features

TOPS/ROPS/FOPS canopy ¹	Battery kill switch
980 mm dozer blade with two 190 mm blade extensions	Cupholders
Exposed counterweight with 4 mm steel tailgate	Foldable and ergonomic pedals
230 mm rubber track	Hydraulically retractable undercarriage from 1360 mm to 980 mm
Double acting auxiliary hydraulics	Upper structure four point tie down
Control console locks	Work light
Horn	Engine with auto shutdown
Hydraulic joystick controls	Hydraulic and travel control lockout
Retractable seat belt	Warranty: 12 months, 2000 hours (whichever occurs first)
Full fuel warning alarm	

1. Roll Over Protective Structure (ROPS) – Meets requirements of ISO 3471. Tip Over Protective Structure (TOPS) – Meets requirements of ISO 12117. Falling Object Protective Structure (FOPS) - Meets requirements of ISO 3449.

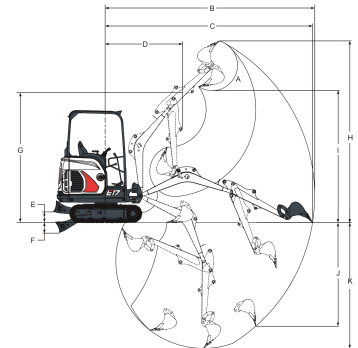
Working Range

(A)	196.0°	(G)	2405.0 mm
(B)	3919.0 mm	(H)	3371.0 mm
(C)	3871.0 mm	(I)	2370.0 mm
(D)	1526.0 mm	(J)	1810.0 mm
(E)	220.0 mm	(K)	2249.0 mm
(F)	204.0 mm		

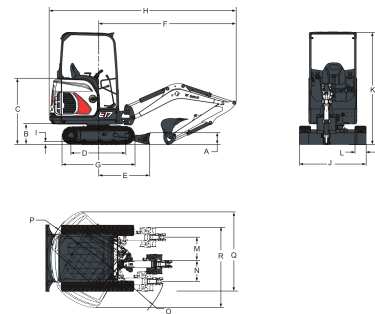
Dimensions

(A)	235.0 mm	(J*)	1360.0 mm
(B)	419.0 mm	(K)	2299.0 mm
(C)	1340.0 mm	(L)	230.0 mm
(D)	1114.0 mm	(M)	433.0 mm
(E)	1045.0 mm	(N)	589.0 mm
(F)	2666.0 mm	(O)	1128.0 mm
(G)	1476.0 mm	(P)	1009.0 mm
(H)	3665.0 mm	(Q)	1801.0 mm
(I)	25.0 mm	(R)	1645.0 mm
(J)	980.0 mm		

Options

TOPS/ROPS cab with heater	Auxiliary hydraulic line on arm
Keyless start	Boom load holding valve
Travel motion alarm	Klac and Lehnhoff couplers
Cab enclosure, vinyl	Object handling certification
Cab/canopy light kit	Deluxe textile suspension seat
Special applications kit	Two speed travel
Long dozer blade	Auxiliary quick couplers
AM/FM MP3 stereo radio	